



GENESIS

RESCUE SYSTEMS

HYDRAULIC CUTTER & COMBI TOOL USER GUIDE

THIS GUIDE COVERS PART NUMBERS

All 9, C25, C30, C50, C165, C185, C195-SL2,
C236, C236 NXTgen, C236-SL2, C270, C365,

MTC

11c, 11c-SL2, 11c-Light, 14c, 15c, 17c, Hand
Vario

CONTENTS

GENERAL INFO	4
ABOUT THE USER GUIDE	4
EXPLANATION OF SYMBOLS	5
LIMITATIONS OF LIABILITY	6
COPYRIGHT	6
WARRANTY CONDITIONS	7
CUSTOMER SERVICE	7
SAFETY	8
INTENDED USE	8-9
RESPONSIBILITY OF USER	10
OPERATING PERSONNEL	11
PERSONAL PROTECTIVE EQUIPMENT	12
SPECIFIC HAZARDS	13-14
HOW TO RESPOND	15
SIGNAGE	16
TECHNICAL DATA	17
CUTTERS	17
COMBINATION	19
OPERATING CONDITIONS	20
TYPE PLATE	20
DESIGN AND FUNCTION	21
OVERVIEW OF DEVICES	21-24
HYDRAULIC SUPPLY	25
EQUIPMENT CONNECTIONS	26-27
CONTROL HANDLE	28
CHANGING SPREADER TIPS	29
CHANGING BLADES	30
POSSIBLE APPLICATIONS	31
SAFETY INFORMATION	31
CUTTING	31-32
SPREADING	33
PULLING	34
CRUSHING	35
LIFTING	35
CONTINUOUS CUTS MTC	36

TRANSPORT AND STORAGE	37
SAFETY INFORMATION	37
TRANSPORT INSPECTION	37
DISPOSAL OF PACKAGING	38
STORAGE	38
INSTALLATION AND USE	39
SAFETY INFORMATION	39
CHECKING	40
INSTALATION	41
SHUT-DOWN	41
SERVICE	42
SAFETY INFORMATION	42
CARE AND MAINTENANCE	42
MAINTENANCE SCHEDULE	43
TROUBLESHOOTING	44
DISPOSAL	45
NOTES	46-47

GENERAL INFORMATION

About the operating manual

This operating manual provides important information on using the hydraulic rescue cutters and combi tools. Proper compliance with all specified safety instructions and guidelines is a prerequisite for safe work.

Furthermore, adhere to the local accident prevention guidelines and general safety regulations for the region in which the devices are used.

These operating instructions must be carefully read prior to starting any work! They are an inherent part of the product and must be kept in a place that is known and accessible to personnel at all times.

This documentation contains information for operating your equipment. However, you may also find information which may not directly apply to your specific equipment.

All information, technical data, graphics and diagrams contained in these operating instructions are based on the latest data available at the time of the document's creation.

We recommend that, in addition to carefully reading through the operating manual, you be trained on handling the rescue equipment (possible applications, application tactics, etc.) by our qualified trainers.

EXPLANATION OF SYMBOLS

Warnings

Warnings are marked by symbols in this operating manual. The individual instructions are introduced by signal words that express the severity of the hazard.

It is essential to comply with the instructions in order to prevent accidents, injuries and damage to property.



DANGER!

... indicates an imminently dangerous situation that can result in death or serious injury if not avoided.



WARNING!

... indicates a potentially dangerous situation that can result in death or serious injury if not avoided.



CAUTION!

... indicates a potentially dangerous situation that can result in minor or light injuries if not avoided.



ATTENTION!

... indicates a potentially dangerous situation that can result in material damage if not avoided.



NOTE!

... highlights useful tips and recommendations, as well as information for efficient, trouble-free operation.

LIMITATIONS OF LIABILITY

All information and instructions in this operating manual have been compiled in keeping with applicable standards and guidelines, the current state of technology, and our many years of knowledge and experience.

The manufacturer assumes no liability for damage due to:

- Failure to comply with the operating manual
- Unintended use
- Assignment of untrained personnel
- Unauthorized modifications
- Technical changes
- Use of non-approved replacement parts
- Use of non-original replacement parts

The actual scope of delivery can vary from the explanations and graphic representations provided in this manual in the case of special versions, or due to technical changes.

COPYRIGHT

All texts, diagrams, drawings and images in this operating manual may be used without restriction and without any prior approval.



NOTE!

Further information, images and drawings can be found on our website
www.genesisrescue.com

WARRANTY CONDITIONS

The warranty conditions can be found as a separate document in the sales documentation.

CUSTOMER SERVICE

Contact your local Genesis sales representative. If you are unsure you can contact Genesis Rescue Systems direct at.

American Rescue Technology
2780 Culver Ave.
Kettering, Ohio
45429

Tel: 1.937.293.6240
Fax: 1.937.293.7049
www.genesisrescue.com



NOTE!

When contacting customer service please state your equipment's designation, type and production year. These details can be found on the equipment type plate.

SAFETY

This section of the operating manual provides a comprehensive overview of all important safety aspects for optimal protecting operating personnel and for safe, trouble-free operation.

Significant hazards may occur if the handling and safety instructions in this manual are not complied with.

INTENDED USE

The hydraulic battery-powered devices are designed and tested exclusively for the intended applications described here. All other activities are strictly forbidden.

CONVENTIONAL DEVICES (All 9, C25, C30, C50, C165, C185, C195-SL2, C236, C236 NXTgen, C236-SL2, C270, C365, MTC)

- All of the cutters are designed as one-man devices and may therefore be operated by one person only.
- The devices serve exclusively for the cutting of doors and roof pillars, posts and sills, the rims and spokes of steering wheels.
- The rear cutter section should be used whenever possible for separating solid material as this is equipped with special round material cutters.
- In industrial applications the equipment can also be used for cutting pipes, construction steel, profiles, sheets and cables.

COMBINATION TOOLS (11c, 11c-SL2, 11c-Light 14c, 15c, 17c, Hand Vario)

- All combi tools are designed as one-man devices and therefore may be operated by one person only.
- The devices serve exclusively for the cutting of doors and roof pillars, posts and sills, the rims and spokes of steering wheels.
- The rear cutter section should be used whenever possible for separating solid material as this is equipped with special round material cutters.

- In industrial applications the equipment can also be used for cutting pipes, construction steel, profiles, sheets and cables.
- In addition, the combi tools can be used for opening doors, lifting vehicles, pushing away vehicle parts and squeezing tubes.
- The chain set is to be used exclusively for pulling.



WARNING!
Improper use can be dangerous!

Any improper or unintended use of the devices can be hazardous!

Therefore, make absolutely sure that:

- » **The devices are used only for the applications stated above.**

RESPONSIBILITY OF THE CUSTOMER

In addition to the health and safety instructions in this operating manual, one must adhere to the safety, accident prevention, and environmental protection guidelines for the region in which the equipment is used. Particularly applicable in this regard:

- The customer must be familiar with the applicable health and safety provisions and in a hazard analysis identify other hazards that may exist at the equipment's installation site due to the special working conditions.
- The customer must clearly regulate and specify responsibilities for installation, operation, maintenance and cleaning.
- The customer must ensure that all personnel who handle the equipment have fully read and understood the operating manual.
- In addition, at regular intervals, the operator must train personnel and inform them of the hazards of working with the equipment.

Moreover, the customer is responsible for ensuring that the equipment is always in technically faultless condition. Consequently, the following applies:

- After each use, and at least once a year, a visual inspection of the equipment must be carried out by a trained individual (according to GUV-G 9102 or country-specific guidelines).
- Every three years, or if you have doubts about the safety or reliability of the equipment, functional testing and stress testing must be carried out (according to GUV-G 9102 or country-specific guidelines).

OPERATING PERSONNEL

The following qualifications are cited in the operating instructions for the various activity areas:

- **Trained individual**
is informed through training offered by the customer about the tasks assigned to him and the possible dangers of improper conduct.
- **Specialist**
is someone who, due to specialized training, skills and experience, as well as knowledge of the applicable stipulations by the manufacturer, is capable of executing the tasks assigned to him or her and of independently recognizing possible hazards.



WARNING!

Inadequate training can result in injuries!
Improper handling of the equipment can lead to serious injury or material damage.

Therefore, make absolutely sure to:

- » allow particular tasks to be carried out only by the persons stated in the relevant chapter of this manual.
- » When in doubt, call in specialists immediately.



NOTE!

The equipment may not be used by personnel who have consumed alcohol, medication or drugs!

PERSONAL PROTECTIVE EQUIPMENT

Wearing personal protective equipment (PPE) is essential to minimize the risks to operating personnel when working with the hydraulic rescue devices. It is essential to wear the following protective clothing for all work:



Protective work clothing

Tight-fitting work clothing with tight sleeves and no protruding parts must be worn when working. It mostly serves to protect against entanglement by moving equipment parts.



Safety shoes

Steel-toed safety shoes must always be worn as protection against heavy falling parts and from slipping on slick surfaces.



Work gloves

Work gloves must be worn when working with the equipment to provide protection from sharp edges and shards of glass.



Helmet with face shield

A helmet with face shield must be worn for protection against flying or falling parts and shards of glass.



Protective goggles

Protective goggles must also be worn in addition to the face shield in order to protect the eyes from flying objects.

The following must also be worn for certain work:



Ear protectors

In addition to the basic protective equipment, ear protectors must also be worn to protect your hearing.

SPECIFIC HAZARDS

The hazards arising from the risk analysis are listed in the following section.

Follow the safety instructions listed here and the warnings in the other sections of this manual to minimize potential health hazards and avoid dangerous situations.

ELECTRICITY



DANGER!

Danger of fatal electric shock!

There is an imminent life-threatening danger if live parts are touched. Damage to insulation or to specific components can pose a fatal hazard.

Therefore:

- » If the insulation is damaged, immediately disconnect the power supply and arrange for repairs.
- » Allow only qualified electricians to work on the electrical equipment.
- » For all work on the electrical equipment, it must be disconnected from the power source, and it must be checked that the device is powered off.
- » Prior to maintenance, cleaning and repair work, the power supply must be switched off and secured to prevent it from being switched back on again.
- » Do not bypass or disable fuses. When changing the fuses, ensure that they have the correct amperage.
- » Keep moisture away from live parts. This can lead to a short-circuit.

NOISE



WARNING!

Noise can damage hearing!

The noise occurring in the work area can cause severe hearing damage.

Therefore:

- »» You should also wear ear protectors when carrying out certain noise-producing tasks.
- »» Do not stay in the hazardous area longer than necessary.

HYDRAULIC POWER



WARNING!

Hydraulic power hazard!

Serious injury can result due to the released hydraulic forces and escaping hydraulic oil.

Therefore:

- »» Constantly monitor the device during the work procedure and set down if necessary.
- »» Inspect the hose lines and devices for damage after every use.
- »» Avoid skin contact with the hydraulic oil (wear protective gloves).
- »» Immediately remove the hydraulic oil from wounds and consult a doctor.

SAFETY DEVICES

Safety valve for SKS couplings

If the return line is not correctly coupled such that the oil cannot return then a safety valve integrated into the control handle actuates in order to protect the equipment and the operator. This causes hydraulic oil to seep harmlessly from the end of the handle.

Move the switching valve on the hydraulic power unit immediately to the „0“ position and connect the coupling parts together correctly.

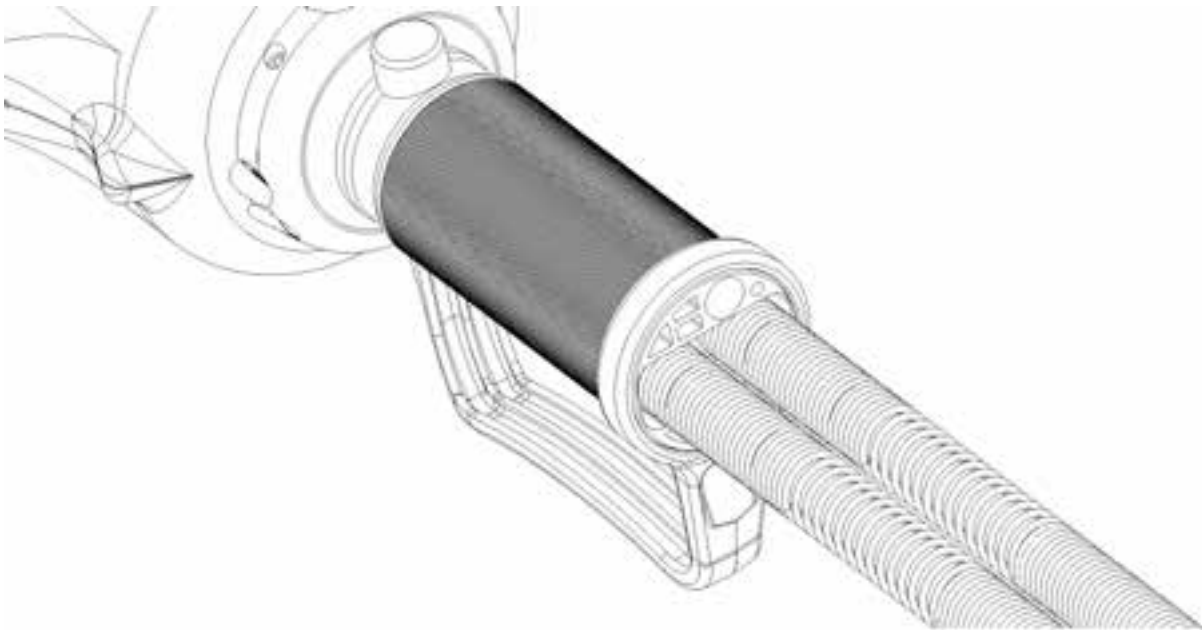

HOW TO RESPOND IN THE EVENT OF DANGER OR ACCIDENTS

Preventive measures

- Always be prepared for accidents
- Keep first aid equipment (first aid kit, blankets, etc.) at hand
- Familiarize personnel with accident alarms, first aid gear, and emergency equipment
- Keep entryways clear for emergency vehicles

In the event of an accident

- Shut down equipment immediately
- Initiate first aid measures
- Get people out of the danger zone
- Inform the responsible parties at the site of the incident
- Notify a doctor and/or the fire brigade
- Clear entryways for emergency vehicles

SIGNAGE

The equipment bears the following WARNING label.



Comply with the operating manual

Do not use the marked equipment until you have read this operating manual.



WARNING!

Danger of injury due to illegible symbols!

Over time, stickers and symbols on the equipment can become soiled or otherwise illegible.

Therefore, make absolutely sure to:

- » Keep all safety, warning and operating information on the device easily legible.
- » Replace damaged signs and stickers immediately.

TECHNICAL DATA

VERSION ACT.2.2016

ART.593.535.0

CERTIFICATIONS

- NFPA 1936:2015 COMPLIANT
- ISO 9001:2008

GENESIS

RESCUE SYSTEMS

WWW.GENESISRESCUE.COM

ALL - 9 CUTTER

The All-9 cutter boast a max cutting force of 369,000 lbf . This tool is tested and certified to cut 9 sized materials in all catagories.



SPECIFICATIONS

LENGTH(IN/MM) - 33.7/855

WIDTH(IN/MM) - 10.8/273

DEPTH(IN/MM) - 9.2/234

WEIGHT(LBS/KGS) - 48.3/21.9

POWER SOURCE - POWER UNIT

OPERATING PRESSURE(Psi/BAR) - 10,500/720

OPENING(IN/MM) - 7.1/180

MAX CUTTING FORCE(LBF/KN) - 369,000/1640

NFPA 1936 COMPLIANT - YES

NFPA 1936 LEVEL RATING - A9 | B9 | C9 | D9 | E9

SPECIFICATIONS



LOOKING FOR TRAINING

GENESIS
RESCUE SYSTEMS

TECHNICAL DATA

VERSION PCT.5.7.2014

ART.106.561.2

GENESIS

RESCUE SYSTEMS

WWW.GENESISRESCUE.COM

C25 MINI CUTTER HSM

ACCESSORIES

- LED TOOL LIGHT - ART.813.595.0

The C25 Mini Cutter is ideal for cutting chains, rebar, and other high strength material.

SPECIFICATIONS

LENGTH(IN/MM) - 17.6/448
WIDTH(IN/MM) - 7/179
DEPTH(IN/MM) - 9.4/239
WEIGHT(LBS/KGS) - 17/7.7
OPERATING PRESSURE(PSI/BAR) - 10,500/720
MAX CUTTING FORCE(LBF/KN) - 42,939/191
BLADE OPENING(IN/MM) - 1/25



SPECIFICATIONS



LOOKING FOR TRAINING

TECHNICAL DATA

VERSION PCT.2.2016

ART.281.538.9

GENESIS

RESCUE SYSTEMS

WWW.GENESISRESCUE.COM

C30 CUTTER

ACCESSORIES

- LED TOOL LIGHT - ART.813.595.0

Constructed of high strength, aircraft grade, aluminum alloy forgings with a wear resistant anodized finish. The blades on the C-30 Cutter are forged steel.

SPECIFICATIONS

LENGTH(IN/MM) - 11/280
WIDTH(IN/MM) - 2.5/64
DEPTH(IN/MM) - 6.5/165
WEIGHT(LBS/KGS) - 8/3.6
POWER SOURCE - POWER UNIT
OPERATING PRESSURE(PSI/BAR) - 10,500/720
OPENING(IN/MM) - 1.5/38
MAX CUTTING FORCE(LBF/KN) - 31,000/138
NFPA 1936 COMPLIANT - NO
NFPA 1936 LEVEL RATING - ----



SPECIFICATIONS



LOOKING FOR TRAINING

TECHNICAL DATA

VERSION PCT.2.2016

ART.283.339.5

CERTIFICATIONS

- NFPA 1936:2015 COMPLIANT
- ISO 9001:2008

GENESIS

RESCUE SYSTEMS

WWW.GENESISRESCUE.COM

C50 CUTTER

ACCESSORIES

- LED TOOL LIGHT - ART.813.595.0

Constructed of high strength, aircraft grade, aluminum alloy forgings with a wear resistant anodized finish. The blades on the C-50 Cutter are forged steel.

SPECIFICATIONS

LENGTH(IN/MM) - 13.4/341

WIDTH(IN/MM) - 2.8/70

DEPTH(IN/MM) - 5.2/131

WEIGHT(LBS/KGS) - 9.9/4.5

POWER SOURCE - POWER UNIT

OPERATING PRESSURE(PSI/BAR) - 10,500/720

OPENING(IN/MM) - 1.8/45

MAX CUTTING FORCE(LBF/KN) - 31,000/138

NFPA 1936 COMPLIANT - YES

NFPA 1936 LEVEL RATING - A4 | B3 | C2 | D4 | E3



SPECIFICATIONS



LOOKING FOR TRAINING

TECHNICAL DATA

VERSION PCT.2.2016

ART.593.207.6

CERTIFICATIONS

- NFPA 1936:2015 COMPLIANT
- ISO 9001:2008

GENESIS

RESCUE SYSTEMS

WWW.GENESISRESCUE.COM

C165 CUTTER

ACCESSORIES

- LED TOOL LIGHT - ART.813.595.0

SPECIFICATIONS

LENGTH(IN/MM) - 29/739

WIDTH(IN/MM) - 8.7/220

DEPTH(IN/MM) - 8.7/220

WEIGHT(LBS/KGS) - 37/16.8

POWER SOURCE - POWER UNIT

OPERATING PRESSURE(PSI/BAR) - 10,500/720

OPENING(IN/MM) - 6.4/163

MAX CUTTING FORCE(LBF/KN) - 144,000/642

NFPA 1936 COMPLIANT - YES

NFPA 1936 LEVEL RATING - A8 | B6 | C6 | D7 | E9



SPECIFICATIONS



LOOKING FOR TRAINING

GENESIS
RESCUE SYSTEMS

ART.108.042.3

CERTIFICATIONS

- NFPA 1936:2015 COMPLIANT
- ISO 9001:2008

GENESIS

RESCUE SYSTEMS

WWW.GENESISRESCUE.COM

C195 NXTGEN CUTTER



NXTgen replaceable blade inserts allow for this cutter to cut UHSS and Boron more effectively.

SPECIFICATIONS

LENGTH(IN/MM) - 28.9/736

WIDTH(IN/MM) - 9.3/236

DEPTH(IN/MM) - 8.3/212

WEIGHT(LBS/KGS) - 37.3/16.9

POWER SOURCE - POWER UNIT

OPERATING PRESSURE(PSI/BAR) - 10,000/700

OPENING(IN/MM) - 7.1/180

NFPA 1936 COMPLIANT - YES

NFPA 1936 LEVEL RATING - A8 | B9 | C7 | D9 | E9

SPECIFICATIONS



LOOKING FOR TRAINING

TECHNICAL DATA

VERSION ACT.2.2016

ART.105.922.6

CERTIFICATIONS

- NFPA 1936:2015 COMPLIANT
- ISO 9001:2008

GENESIS

RESCUE SYSTEMS

WWW.GENESISRESCUE.COM

C185 NXTgen CUTTER

ACCESSORIES

- LED TOOL LIGHT - ART.813.595.0
- C185 BLADE INSERTS - ART.106.156.8

This tool is equip with Genesis NXTgen blade inserts. These inserts allow the cutter to be more effective when cutting UHSS and Boron steel.

SPECIFICATIONS

LENGTH(IN/MM) - 31.5/800

WIDTH(IN/MM) - 9.1/232

DEPTH(IN/MM) - 9.1/230

WEIGHT(LBS/KGS) - 39.5/17.9

OPERATING PRESSURE(PSI/BAR) - 10,500/720

OPENING(IN/MM) - 7.1/180

MAX CUTTING FORCE(LBF/KN) - 110,830/493

NFPA 1936 COMPLIANT - YES

NFPA 1936 LEVEL RATING - A7 | B9 | C7 | D9 | E9

SHIPPING WEIGHT(LBS/KGS) - 43.9/19.9

BOX SIZE(FT3/M3) - 2.16/0.061

BOX DIMENTIONS(IN/MM) - 36X11X6/914X292X229



SPECIFICATIONS



LOOKING FOR TRAINING

GENESIS
RESCUE SYSTEMS

ART.593.585.7

CERTIFICATIONS

- NFPA 1936:2015 COMPLIANT
- ISO 9001:2008

GENESIS

RESCUE SYSTEMS

WWW.GENESISRESCUE.COM

C236 CUTTER

ACCESSORIES

- LED TOOL LIGHT - ART.813.595.0

SPECIFICATIONS

LENGTH(IN/MM) - 33/833
WIDTH(IN/MM) - 10.6/269
DEPTH(IN/MM) - 9.4/239
WEIGHT(LBS/KGS) - 44.8/20.3
POWER SOURCE - POWER UNIT
OPERATING PRESSURE(PSI/BAR) - 10,500/720
OPENING(IN/MM) - 7.9/200
MAX CUTTING FORCE(LBF/KN) - 236,000/1050
NFPA 1936 COMPLIANT - YES
NFPA 1936 LEVEL RATING - A8 B9 C8 D9 E9



SPECIFICATIONS



LOOKING FOR TRAINING

TECHNICAL DATA

VERSION PCT.2.2016

ART.106.949.8

CERTIFICATIONS

- NFPA 1936:2015 COMPLIANT
- ISO 9001:2008

GENESIS

RESCUE SYSTEMS

WWW.GENESISRESCUE.COM

C236 NXTGEN CUTTER

ACCESSORIES

- LED TOOL LIGHT - ART.813.595.0

NXTgen replaceable blade inserts allow for this cutter to cut UHSS and Boron more effectively.

SPECIFICATIONS

LENGTH(IN/MM) - 33/833

WIDTH(IN/MM) - 10.6/269

DEPTH(IN/MM) - 9.4/239

WEIGHT(LBS/KGS) - 44.8/20.3

POWER SOURCE - POWER UNIT

OPERATING PRESSURE(PSI/BAR) - 10,500/720

OPENING(IN/MM) - 7.9/200

MAX CUTTING FORCE(LBF/KN) - 236,000/1050

NFPA 1936 COMPLIANT - YES

NFPA 1936 LEVEL RATING - A8 | B9 | C8 | D9 | E9



SPECIFICATIONS



LOOKING FOR TRAINING

ART.108.757.2

CERTIFICATIONS

- NFPA 1936:2015 COMPLIANT
- ISO 9001:2008



C236-SL2 CUTTER

NXTgen replaceable blade inserts allow for this cutter to cut UHSS and Boron more effectively.



SPECIFICATIONS

LENGTH(IN/MM) - 33/833

WIDTH(IN/MM) - 10.2/260

DEPTH(IN/MM) - 8.7/221

WEIGHT(LBS/KGS) - 43.2/19.6

POWER SOURCE - POWER UNIT

OPERATING PRESSURE(PSI/BAR) - 10,500/720

OPENING(IN/MM) - 8.2/210

NFPA 1936 COMPLIANT - YES

NFPA 1936 LEVEL RATING - A8 | B9 | C8 | D9 | E9

GENESIS IS
TRAINING
FOLLOW US



TECHNICAL DATA

VERSION PCT.2.2016

ART.593.209.2

CERTIFICATIONS

- NFPA 1936:2015 COMPLIANT
- ISO 9001:2008

GENESIS

RESCUE SYSTEMS

WWW.GENESISRESCUE.COM

C270 CUTTER

ACCESSORIES

- LED TOOL LIGHT - ART.813.595.0

SPECIFICATIONS

LENGTH(IN/MM) - 31.789

WIDTH(IN/MM) - 8.7/220

DEPTH(IN/MM) - 8.7/220

WEIGHT(LBS/KGS) - 38/17.3

POWER SOURCE - POWER UNIT

OPERATING PRESSURE(PSI/BAR) - 10,500/720

OPENING(IN/MM) - 11/278

MAX CUTTING FORCE(LBF/KN) - 157,000/699

NFPA 1936 COMPLIANT - YES

NFPA 1936 LEVEL RATING - A7 | B8 | C7 | D8 | E9



SPECIFICATIONS



LOOKING FOR TRAINING

GENESIS
RESCUE SYSTEMS

TECHNICAL DATA

VERSION PCT.2.2016

ART.105.048.4

CERTIFICATIONS

- NFPA 1936:2015 COMPLIANT
- ISO 9001:2008

GENESIS

RESCUE SYSTEMS

WWW.GENESISRESCUE.COM

C365 CUTTER

ACCESSORIES

- LED TOOL LIGHT - ART.813.595.0

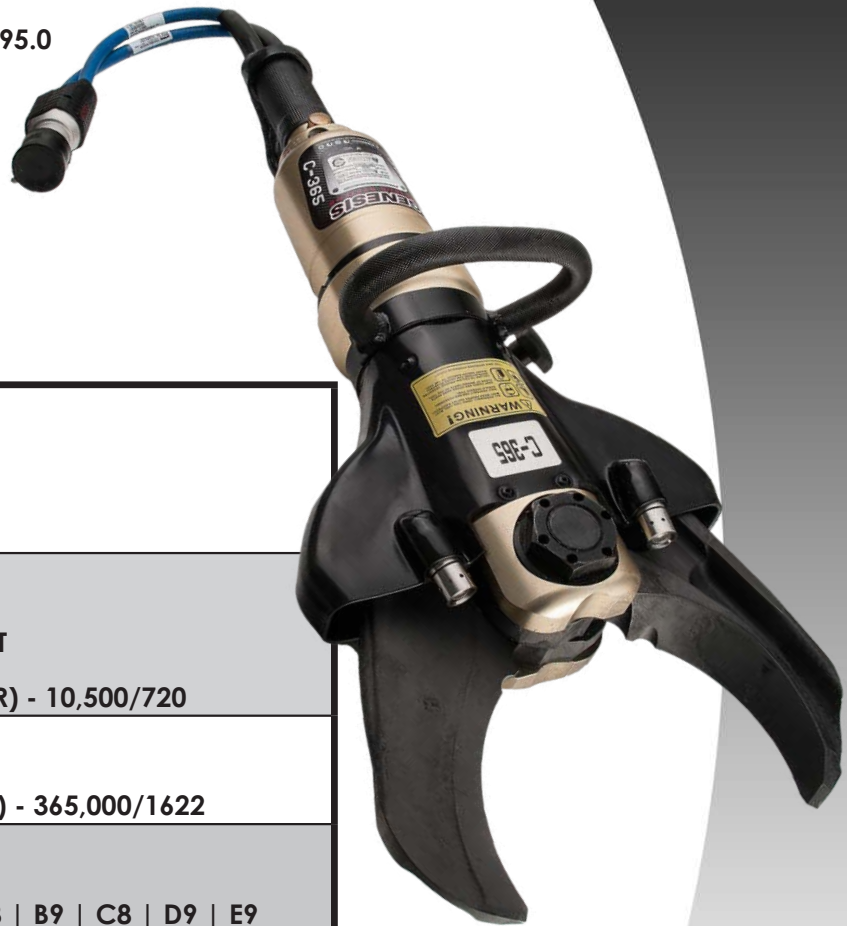

SPECIFICATIONS

LENGTH(IN/MM) - 31.9/811

WIDTH(IN/MM) - 10/273

DEPTH(IN/MM) - 9.3/237

WEIGHT(LBS/KGS) - 48.5/22

POWER SOURCE - POWER UNIT

OPERATING PRESSURE(PSI/BAR) - 10,500/720

OPENING(IN/MM) - 6.9/175

MAX CUTTING FORCE(LBF/KN) - 365,000/1622

NFPA 1936 COMPLIANT - YES

NFPA 1936 LEVEL RATING - A8 | B9 | C8 | D9 | E9

SPECIFICATIONS



LOOKING FOR TRAINING

TECHNICAL DATA

VERSION PCT.2.2016

ART.593.616.0

CERTIFICATIONS

- NFPA 1936:2015 COMPLIANT
- ISO 9001:2008

GENESIS

RESCUE SYSTEMS

WWW.GENESISRESCUE.COM

MASS TRANSIT CUTTER

ACCESSORIES

- LED TOOL LIGHT - ART.813.595.0

Special serrated surface for aggressive cutting. The material that is cut, are automatically removed.

SPECIFICATIONS

LENGTH(IN/MM) - 30.3/770
WIDTH(IN/MM) - 6.4/162
DEPTH(IN/MM) - 11.3/288
WEIGHT(LBS/KGS) - 43/19.5
OPERATING PRESSURE(PSI/BAR) - 10,000/700
BLADE OPENING(IN/MM) - 4.7/120
MAX CUTTING FORCE(LBF/KN) - 69,300/308
NFPA 1936 COMPLIANT - YES
NFPA 1936 LEVEL RATING - A4 B3 C5 D6 E6
SHIPPING WEIGHT(LBD/KGS) - 48/21.8
BOX SIZE(FT3/M3) - 2.16/0.061
BOX DIMENTIONS(IN/MM) - 36X11X6/914X292X229

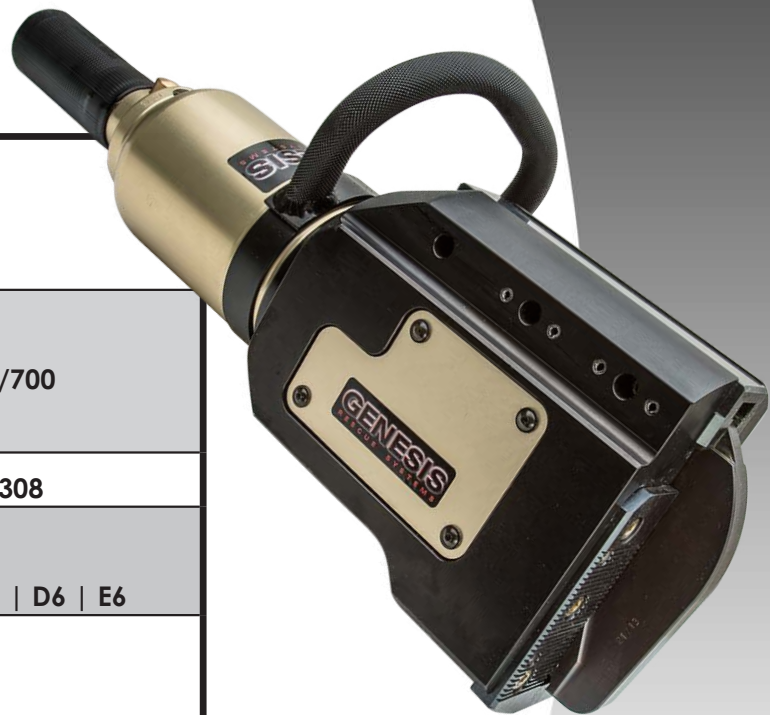

SPECIFICATIONS



LOOKING FOR TRAINING

ART.105.595.4

CERTIFICATIONS

- NFPA 1936:2015 COMPLIANT
- ISO 9001:2008

GENESIS

RESCUE SYSTEMS

WWW.GENESISRESCUE.COM

11C VARIO

ACCESSORIES

- LED TOOL LIGHT - ART.813.595.0
- MECHANICAL RAM - ART.105.647.8

The 11c vario is a ideal tool for first responders, usar teams, and tactical teams. This tool offers lightweight and ergonomic design.

SPECIFICATIONS

LENGTH(IN/MM) - 28/710
WIDTH(IN/MM) - 7.7/195
DEPTH(IN/MM) - 8.9/225
WEIGHT(LBS/KGS) - 23.8/10.8
OPERATING PRESSURE(PSI/BAR) - 10,500/720
SPREADING DISTANCE(IN/MM) - 10.4/265
MAX CUTTING FORCE(LBF/KN) - 72,838/324
MAX SPREADING FORCE(LBF/KN) - 132,975/591
NFPA 1936 COMPLIANT - YES
NFPA 1936 LEVEL RATING - A6 B5 C6 D6 E7
LOWEST SPREADING FORCE(LBF/KN) - 7,200/32
HIGHEST SPREADING FORCE(LBF/KN) - 9,100/40.5
LOWEST PULLING FORCE(LBF/KN) - 5,850/26
HIGHEST PULLING FORCE(LBF/KN) - 8,325/37
SHIPPING WEIGHT(LBS/KGS) - 29.8/13.5
BOX SIZE(FT3/M3) - 2.16/0.061
BOX DIMENTIONS(IN/MM) - 36X11X6/914X292X229

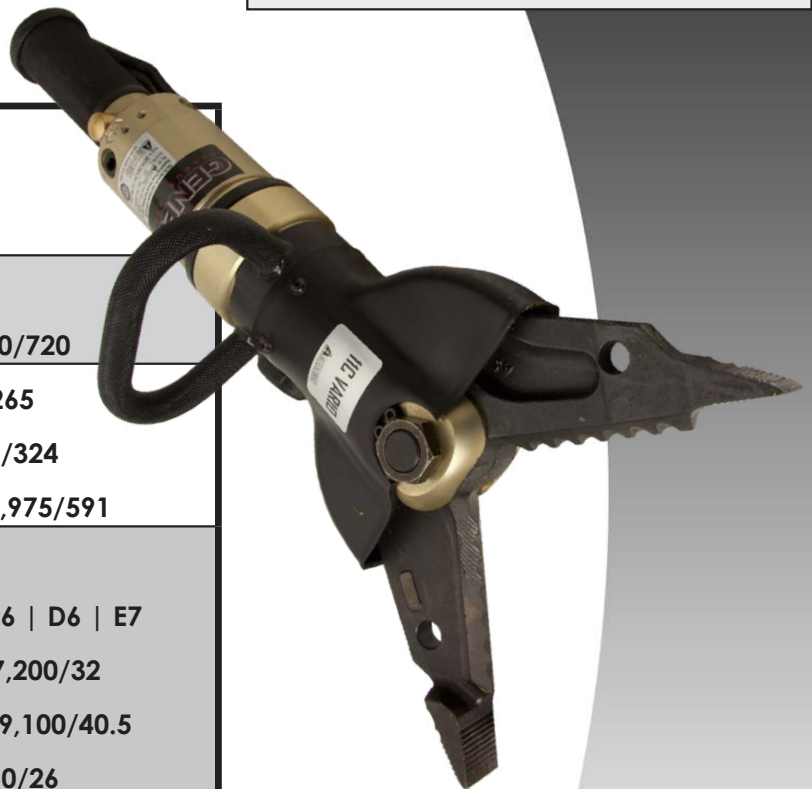

SPECIFICATIONS



LOOKING FOR TRAINING

TECHNICAL DATA

VERSION ACT.3.2016

ART.106.258.0

CERTIFICATIONS

- NFPA 1936:2015 COMPLIANT
- ISO 9001:2008

GENESIS

RESCUE SYSTEMS

WWW.GENESISRESCUE.COM

14C VARIO

ACCESSORIES

- LED TOOL LIGHT - ART.813.595.0
- MECHANICAL RAM - ART.105.647.8

Paired with a mechanical ram this tool can do it all. With a Max cutting force of 110k and a LSF of almost 9k this tool is the perfect balance of size and performance.

SPECIFICATIONS

LENGTH(IN/MM) - 32.4/825
WIDTH(IN/MM) - 9.3/235
DEPTH(IN/MM) - 9/230
WEIGHT(LBS/KGS) - 33/15
POWER SOURCE - N/A
OPERATING PRESSURE(PSI/BAR) - 10,500/720
SPREADING DISTANCE(IN/MM) - 14.2/360
MAX CUTTING FORCE(LBF/KN) - 110,381/491
MAX SPREADING FORCE(LBF/KN) - 176,025/783
NFPA 1936 COMPLIANT - YES
NFPA 1936 LEVEL RATING - A6 B8 C6 D8 E7
LOWEST SPREADING FORCE(LBF/KN) - 8,655/38.5
HIGHEST SPREADING FORCE(LBF/KN) - 9,554/42.5
LOWEST PULLING FORCE(LBF/KN) - 8,768/39
HIGHEST PULLING FORCE(LBF/KN) - 10,903/48.5



SPECIFICATIONS



LOOKING FOR TRAINING

TECHNICAL DATA

VERSION ACT.3.2016

ART.106.331.4

CERTIFICATIONS

- NFPA 1936:2015 COMPLIANT
- ISO 9001:2008

GENESIS

RESCUE SYSTEMS

WWW.GENESISRESCUE.COM

15C VARIO

ACCESSORIES

- LED TOOL LIGHT - ART.813.595.0

The 15c vario is a ideal tool for first responders. Unlike the 14c the 15c has removable tips. This tool offers a light-weight ergonomic design.

SPECIFICATIONS

LENGTH(IN/MM) - 32.7/830
WIDTH(IN/MM) - 9.3/235
DEPTH(IN/MM) - 9/230
WEIGHT(LBS/KGS) - 34.8/15.8
OPERATING PRESSURE(PSI/BAR) - 10,500/720
SPREADING DISTANCE(IN/MM) - 14.4/365
MAX CUTTING FORCE(LBF/KN) - 110,381/491
MAX SPREADING FORCE(LBF/KN) - 176,025/783
NFPA 1936 COMPLIANT - YES
NFPA 1936 LEVEL RATING - A6 B8 C6 D8 E7
LOWEST SPREADING FORCE(LBF/KN) - 8,100/36
HIGHEST SPREADING FORCE(LBF/KN) - 9,900/44
LOWEST PULLING FORCE(LBF/KN) - 9,113/40.5
HIGHEST PULLING FORCE(LBF/KN) - 13,275/59
SHIPPING WEIGHT(LBS/KGS) - 36.6/16.6
BOX SIZE(FT3/M3) - 2.16/0.061
BOX DIMENTIONS(IN/MM) - 36X11X6/914X292X229

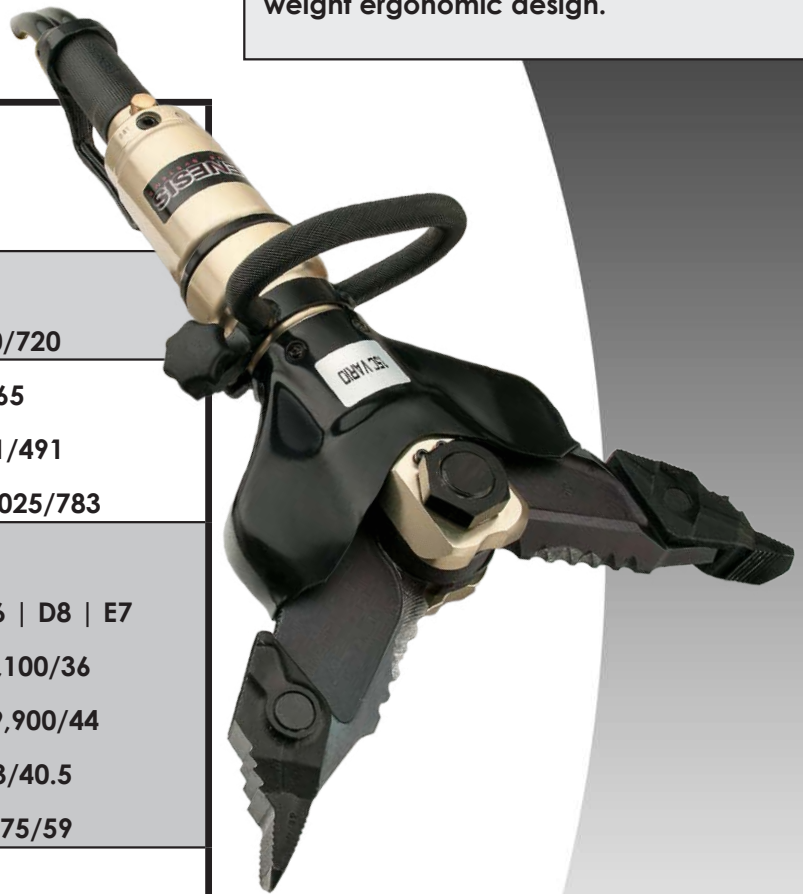

SPECIFICATIONS



LOOKING FOR TRAINING

TECHNICAL DATA

VERSION ACT.3.2016

ART.593.113.4

CERTIFICATIONS

- NFPA 1936:2015 COMPLIANT
- ISO 9001:2008

GENESIS

RESCUE SYSTEMS

WWW.GENESISRESCUE.COM

17C BRUTE VARIO

ACCESSORIES

- LED TOOL LIGHT - ART.813.595.0

SPECIFICATIONS

LENGTH(IN/MM) - 34.1/867
WIDTH(IN/MM) - 9.9/253
DEPTH(IN/MM) - 8.9/227
WEIGHT(LBS/KGS) - 40.3/18.3
OPERATING PRESSURE(PSI/BAR) - 10,500/720
SPREADING DISTANCE(IN/MM) - 16.7/425
MAX PULLING FORCE(LBF/KN) - 14,162/63
MAX SPREADING FORCE(LBF/KN) - 163,211/726
MAX CUTTING FORCE(LBF/KN) - 118,249/526
NFPA 1936 COMPLIANT - YES
NFPA 1936 LEVEL RATING - A7 B9 C7 D9 E9
LOWEST SPREADING FORCE(LBF/KN) - 7,853/34.9
HIGHEST SPREADING FORCE(LBF/KN) - 9,765/43.4
LOWEST PULLING FORCE(LBF/KN) - 8,235/36.6
HIGHEST PULLING FORCE(LBF/KN) - 12,825/57



SPECIFICATIONS



LOOKING FOR TRAINING

ART.593.408.7

VERSION PCT.7.30.2015

GENESIS

RESCUE SYSTEMS

WWW.GENESISRESCUE.COM

HAND VARIO

ACCESSORIES

- LED TOOL LIGHT - ART.813.595.0
- TOOL BACKPACK - ART.EXTBP

The hand vario is a ideal tool for first responders, user teams, and tactical teams. This tool offers a lightweight ergonomic design.

SPECIFICATIONS

LENGTH(IN/MM) - 27/686
WIDTH(IN/MM) - 7/178
DEPTH(IN/MM) - 6.5/165
WEIGHT(LBS/KGS) - 24.7/11.2
OPERATING PRESSURE(PSI/BAR) - 10,500/720
SPREADING DISTANCE(IN/MM) - 10.2/260
SPREADING FORCE(LBF/KN) - 86,175/383
MAX CUTTING FORCE(LBF/KN) - 63,225/281
MAX PULLING FORCE(LBF/KN) - 12,000/53
NFPA 1936 COMPLIANT - N/A
NFPA 1936 LEVEL RATING - A6/B6/C6/D7/E7
LOWEST SPREADING FORCE(LBF/KN) - N/A
HIGHEST SPREADING FORCE(LBF/KN) - N/A
LOWEST PULLING FORCE(LBF/KN) - N/A
HIGHEST PULLING FORCE(LBF/KN) - N/A
SHIPPING WEIGHT(LBD/KGS) - 29/13.2
BOX SIZE(FT3/M3) - 1.69/.047
BOX DIMENTIONS(IN/MM) - 30X12X9/762X305X228



SPECIFICATIONS

  LOOKING FOR TRAINING

ART.105.595.4

CERTIFICATIONS

- NFPA 1936:2015 COMPLIANT
- ISO 9001:2008

GENESIS

RESCUE SYSTEMS
WWW.GENESISRESCUE.COM

11C-SL2 VARIO

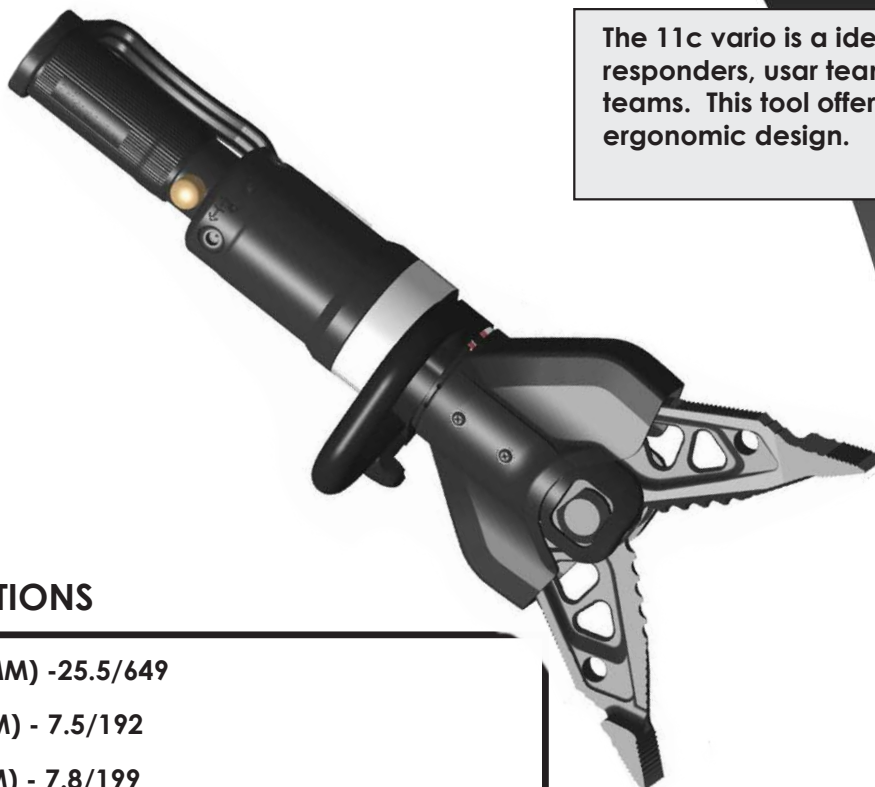

The 11c vario is a ideal tool for first responders, usar teams, and tactical teams. This tool offers lightweight and ergonomic design.

SPECIFICATIONS

LENGTH(IN/MM) - 25.5/649

WIDTH(IN/MM) - 7.5/192

DEPTH(IN/MM) - 7.8/199

WEIGHT(LBS/KGS) - 21.4/9.7

OPERATING PRESSURE(PSI/BAR) - 10,500/720

SPREADING DISTANCE(IN/MM) - 595.2/270

NFPA 1936 COMPLIANT - YES

NFPA 1936 LEVEL RATING - A6 | B7 | C6 | D7 | E7

LOWEST SPREADING FORCE(LBF/KN) - 7,200/32

HIGHEST SPREADING FORCE(LBF/KN) - 9,100/40.5

LOWEST PULLING FORCE(LBF/KN) - 5,850/26

HIGHEST PULLING FORCE(LBF/KN) - 8,325/37

GENESIS IS
TRAINING
FOLLOW US



ART.108.618.1

CERTIFICATIONS

- NFPA 1936:2015 COMPLIANT
- ISO 9001:2008

GENESIS
RESCUE SYSTEMS
WWW.GENESISRESCUE.COM

11C-LIGHT VARIO

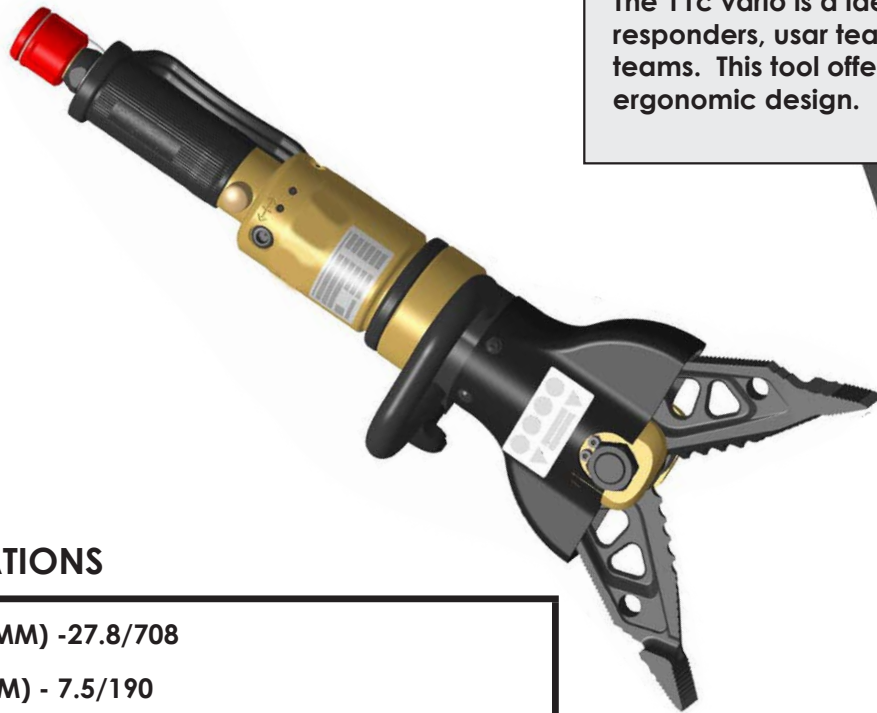

The 11c vario is a ideal tool for first responders, user teams, and tactical teams. This tool offers lightweight and ergonomic design.

SPECIFICATIONS

LENGTH(IN/MM) - 27.8/708

WIDTH(IN/MM) - 7.5/190

DEPTH(IN/MM) - 7.7/196

WEIGHT(LBS/KGS) - 19.6/8.9

OPERATING PRESSURE(PSI/BAR) - 10,500/720

SPREADING DISTANCE(IN/MM) - 595.2/270

NFPA 1936 COMPLIANT - YES

NFPA 1936 LEVEL RATING - A6 | B7 | C6 | D7 | E7

LOWEST SPREADING FORCE(LBF/KN) - 7,200/32

HIGHEST SPREADING FORCE(LBF/KN) - 9,100/40.5

LOWEST PULLING FORCE(LBF/KN) - 5,850/26

HIGHEST PULLING FORCE(LBF/KN) - 8,325/37

GENESIS IS
TRAINING
FOLLOW US



OPERATING CONDITIONS

The permissible temperature range of the E-FORCE devices is between -4°F and +176°F. Reliable operation cannot be guaranteed outside of this range.

Underwater operation

The cutters (exception: Hand Vario) can also be used under water. Do not exceed the maximum submersion depth of 40 metres with this. At this depth the water pressure still has no influence on the hydraulic pressure in the equipment and the hoses.

TYPE PLATE

On all E-FORCE devices, the type plate is located on the body. It shows the serial number, production date, nominal pressure and device designation.

DESIGN AND FUNCTION

Overview of Conventional Hydraulics

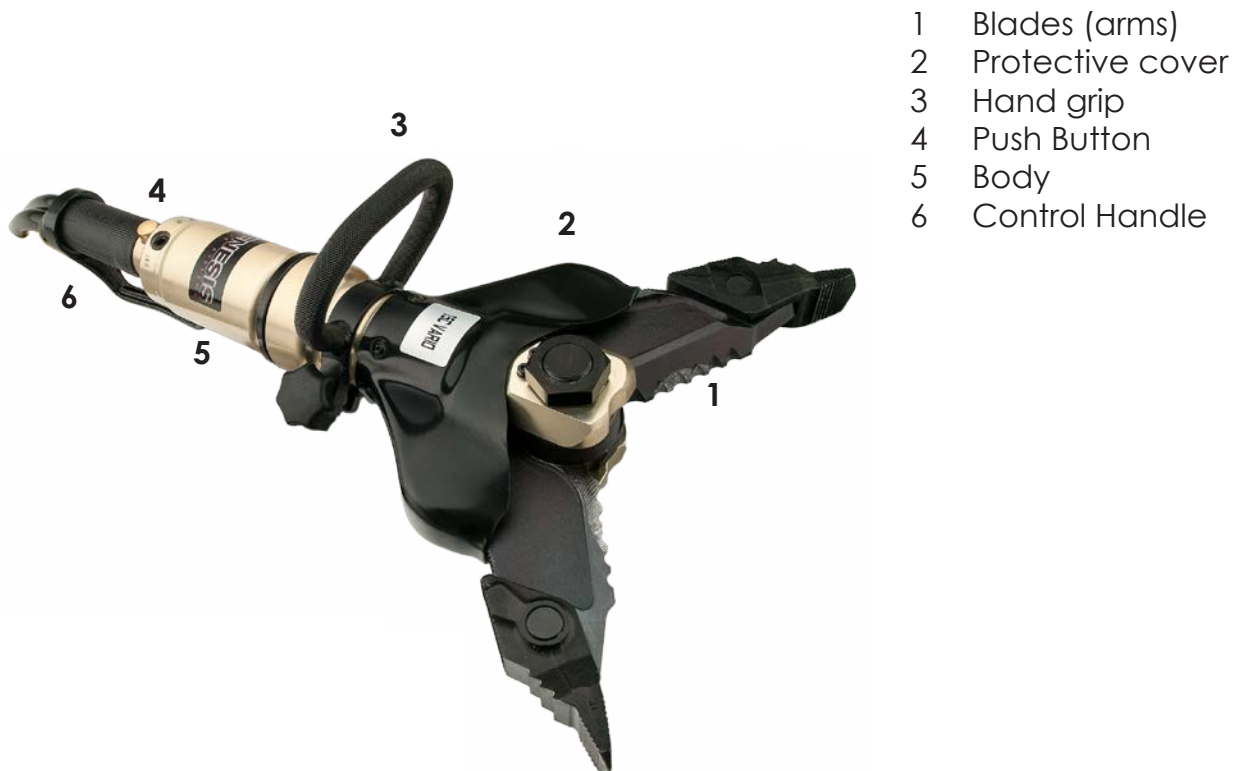

Brief description

Hydraulic cutters are specially designed rescue equipment for cutting bodywork parts. They are used for rescuing trapped or enclosed accident victims. Driven by a hydraulic power unit it is possible to cut door and roof pillars, posts and sills etc. with the cutters.

The speed of movement of the shearing blades is controlled by the greater or lesser degree of force applied to the pushbutton on the handle. The maximum cutting force is only applied when the pushbutton is fully depressed.

HYDRAULIC SUPPLY

Power units and pumps

Only Genesis Rescue power units and hand pumps may be used to drive the cutters. Equipment from other manufacturers can only be used under certain conditions. Therefore always consult with us before operating a device with a power unit from another manufacturer!



ATTENTION !

Before using pumps and power units from other manufacturers always contact Genesis Rescue or an authorized dealer. Incorrect application can lead to hazardous situations for which we cannot accept any liability!

Hoses

The connection of the device with the power unit is carried out via high pressure hoses. Hoses are available various lengths. As the length of the hoses increases so too does the associated pressure loss. With a line length of 50 yards this pressure loss remains acceptable and has no significant effect.



CAUTION !

Do not use damaged hoses !

With damaged hoses there is a danger of escaping hydraulic medium under pressure, or of the hoses whipping around.

Therefore:

»»» The hoses should be subjected to a visual inspection (leak-tightness, surface damage such as kinks) after every use and at least once per year.



- »»» Every three years, or in the event of doubts about the safety or reliability, carry out an additional functional and load test (as per GUV-G 9102 or specific national directive).
- »»» Replace hoses every 10 years! The date (code letters or quarter/year) is specified on the hose bonding.
- »»» Ensure that the hoses are not exposed to tension or torsion (turning).
- »»» Do not kink the hoses or draw them over edges (smallest bend radius 40 mm).
- »»» Do not subject the hoses to high temperatures.
- »»» Protect hoses from contact with materials that can cause damage to the outer covering e.g. acids, alkalis, or solvents.

Hydraulic oil

All cutters are designed and tested for Genesis hydraulic oil ID No. 804932. This oil possesses a particularly high purity level and also works flawlessly at temperatures below zero, down to -20° C.



NOTE !

In addition to the oil mentioned above we recommend:

- »»» AERO Fluid 41 (Shell)
- »»» Univis HVI-13 (Esso)
- »»» Aero-hydraulic 520 (Total)
- »»» Hydraulik DB (Castrol)
- »»» Renolin/MR310 (Fuchs)

EQUIPMENT CONNECTIONS

OSC

Connecting:

Remove the protective cap from the coupling male and the coupling female (Fig. 1). Conflate Single coupling male and female in the bayonet catch (Fig. 2). Hold coupling female on the black slew ring and turn clockwise until the coupling snaps in (Fig. 3). Put protective caps together (Fig. 4). You don't have to switch the power unit to position 0 to connect or disconnect the coupling!

Disconnecting:

Remove the protective caps. Hold coupling female on the black slew ring and turn counter clockwise direction. Turn the black slew ring until you can release the coupling easily. Put protective caps to coupling male and the coupling female.



Fig. 1



Fig. 2



Fig. 3



Fig. 4

PLUG-IN COUPLING

Connecting:

Remove the protective cap from the coupling male. Take hold of the coupling female by the knurled sleeve cover and pull out the protective plug. With one hand take hold of sleeve cover of the coupling female, with the other grasp the coupling male (black) by the hex nut, and press the sleeve cover slightly against the coupling male until the ball bearings engage. Twisting the male coupling slightly when pressing together eases the coupling process.

Disconnecting:

Grasp the coupling male (black) by the hex nut with one hand and with the other take hold of the sleeve cover and draw it back. The disconnecting will cause a few drops of hydraulic oil to escape. Plug in the protective caps immediately.

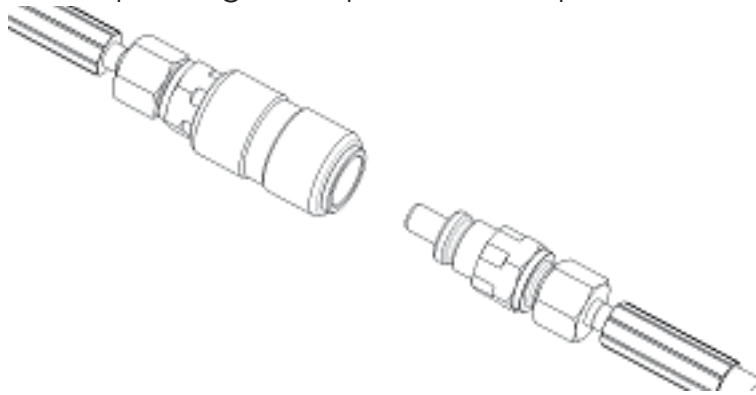

CAUTION !

When coupling SKS connections the power unit operating lever must be in the „0“ position.



NOTE !

A pressure relief connector is fitted to the hydraulic power units and the hand pump, with which a few drops of oil can be discharged from the hoses. This permits re-coupling following pressure increases in de-coupled equipment.

In this case simply insert the pressure relief connector into the coupling sleeve and turn the knurled screw to the right until oil leaks out.

USE OF THE CONTROL HANDLE



The cutter can be operated by the pushbutton on the control handle. The speed of movement of the shearing blades is controlled precisely by the greater or lesser degree of force applied to the pushbutton. The maximum cutting force is only applied when the pushbutton is fully depressed.

Closing the cutters



The primary motion direction of the device (closing) is triggered by pressing the lower tapered (convex) end of the button. The direction of movement is marked on the equipment with the symbol:



Opening the cutters

The cutters are opened with the upper curved (concave) end of the button, which is marked with the following symbol:

Dead-man's switching

If the pushbutton is released then it returns to the neutral position automatically. With this, the device stops still in any position (including under load).

CHANGING THE SPREADER TIPS (S45)

The spreader tips are secured in the spreader arms with collar studs. The studs are secured by a spring-loaded ball and must be pressed out for replacement. After the tips have been replaced, the collar studs can be pushed back through. Check that the studs are seated correctly (pressed completely in).

The holder for the chain set must be mounted in identical fashion. The chain lock must be installed with the latch facing upward.

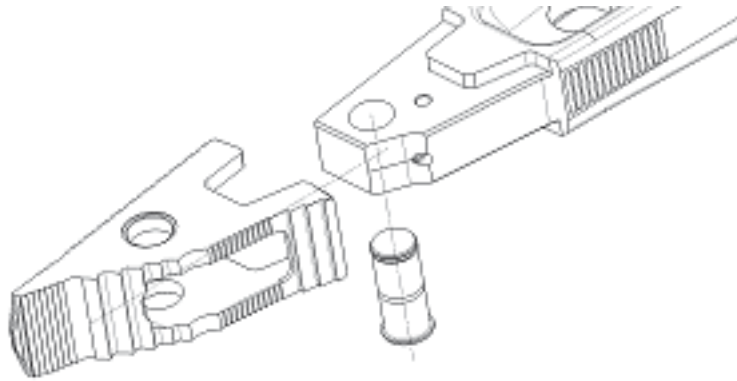

The chain lock is mounted in exactly the same way on the 11c E-FORCE, 14c E-FORCE, and 17c E-FORCE. However, for this the spreader tips must first be removed. To do this, pulling device 2096617 must be attached to 11c E-FORCE, pulling device 2835746 for 14c E-FORCE and pulling device 2836033 for 17c E-FORCE.

REPLACING BLADE INSERTS

During blade replacement, the cutter is fixed in place. Any slipping should be avoided. Replacing the blade requires a soft-face hammer, the roll pins supplied, a punch and the blade inserts themselves. It makes sense to replace both blade inserts so that the cutting behavior is not impaired.



NOTE!

The blade inserts should not be reground, simply cleaning off any soil is recommended.

Procedure:



The cutter is positioned with the type plate pointing upward and is fixed in place. A clamping device, as shown in the illustrations, is not obligatory. When the blade insert is being changed, the battery must be removed from the cutter and not under load. This means that the shear is not completely open or closed. The blade insert for the cutter blade with the smooth surface can now be replaced. The roll pins are knocked out and downward from the punch.



After the roll pins have been knocked out of their position, the blade insert can be pulled out. The use of a forked screwdriver is recommended. If the blade insert cannot be loosened immediately, it can be gently levered out using a punch in the holes.



Next, the cutter is rotated and the blade insert is placed in the cutter blade with no insert. When inserting, make sure that the blade insert does not twist. If the blade inserts cannot be inserted by hand, use the soft-face hammer.



The roll pins are located using a punch and light blows of a hammer from above into the position holes provided for this purpose. Roll pins should be pushed into position until they are flush with the top surface of the blade.

POSSIBLE APPLICATIONS

Safety information



WARNING!

Never reach between the blade arms!



WARNING!

During any work with battery-powered devices, voltage-carrying parts can break or fly off, thereby endangering people. Uninvolved parties must therefore remain a safe distance away or stay in the danger zone only as long as necessary.

Cutting (Cutters, Combination devices)

The devices' cutting capabilities can only be used optimally if they are placed as near as possible to the blades' pivot point (Figure 1).

This means it may be necessary to readjust the device.

The device only achieves full cutting performance when the rocker lever is pressed all the way through. In addition, it can take several seconds for the unit to reach full operating pressure.

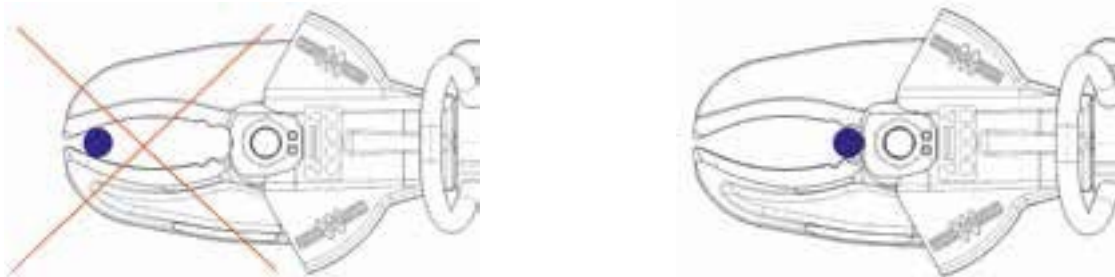

Fig. 1

To prevent the blades from being damaged, they must always be placed at right angles to the material to be cut.

Also, the tips of the blades must not be more than 1/8 in apart during the cutting process. If this value is exceeded, the cutting process must be stopped and then started again.



CAUTION !

Do not sever any parts with loose ends, because this can result in personal injury due to parts flying off.



ATTENTION !

When cutting high-strength vehicle body parts, such as shock absorbers, hinges or steering columns, the shear blades (arms) may cause severe damage.

SPREADING (SPREADERS, COMBI DEVICES)

The spreading function's uses include opening doors, lifting vehicles and other movable loads, pushing vehicle parts away, and squashing tubes and beams. For this, the vehicle must be stably stabilized and supported.

To prevent any sliding during spreading, the arms and tips are fluted inside and out. Whenever possible, the tips should be used only to enlarge a gap, because repositioning the spreader prevents slipping.

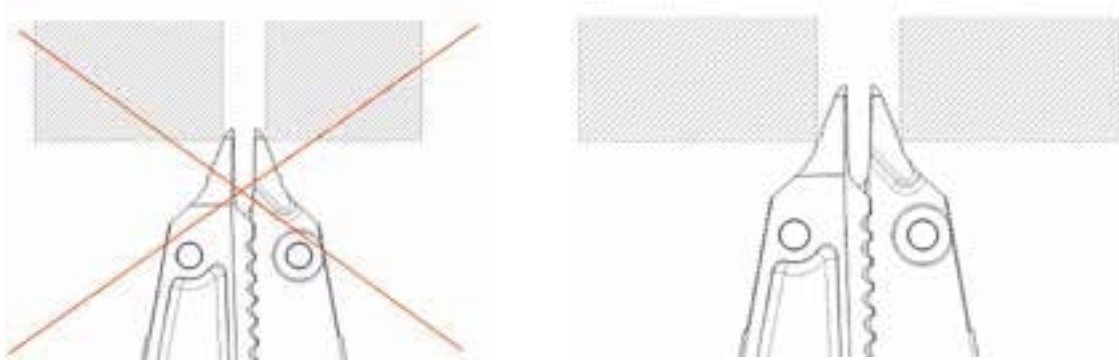

PULLING (SPREADERS, COMBI DEVICES)

After the chain set has been mounted on the spreader tips, the combi device can also be used for pulling.

For this, the chains must be tightly tensioned and must be tensed only in the pulling direction. To tension the chain, only one lock can be pressed in, so that the chain can be pulled through the holder.

If the range of movement is not sufficient, tension chains or other means must be used so that the spreader can be reopened and the chain re-tensioned.

**ATTENTION!**

Store the pulling chains with locks mounted about 4-8 in from the end. Check the chains prior to every use. Check that the weight does not stress the tip of the hook, but lies in the middle of the hook instead.

- » Do not make any repairs on your own.
- » Do not stress the chains beyond the permitted load carrying capacity.
- » Do not load with a jerking movement.
- » Do not galvanize or paint the chains.
- » Do not shorten the chain by knotting it.
- » Do not subject the chains to heat stress.
- » Use the chains and accessories only between -40°F and $+392^{\circ}\text{F}$.
- » During all maintenance work, observe the applicable safety regulations
- » Chains must only be used for lashing. Lifting loads is not permitted.

**ATTENTION!**

Chains must not be used if:

- » Deformations, cracks, signs of corrosion are present.
- » The wire diameter of the chain link has decreased by 10% of the nominal thickness.
- » An individual chain link has been permanently stretched.
- » An individual link has been enlarged by more than 2%.
- » The internal chain pitch over a measuring distance of 11 chain links has increased by more than 2%.

CRUSHING (SPREADERS, COMBI DEVICES)

Pipes and other hollow profiles are crushed by closing the spreader arms. With combi devices, however, crushing is only to be performed in the tip area.

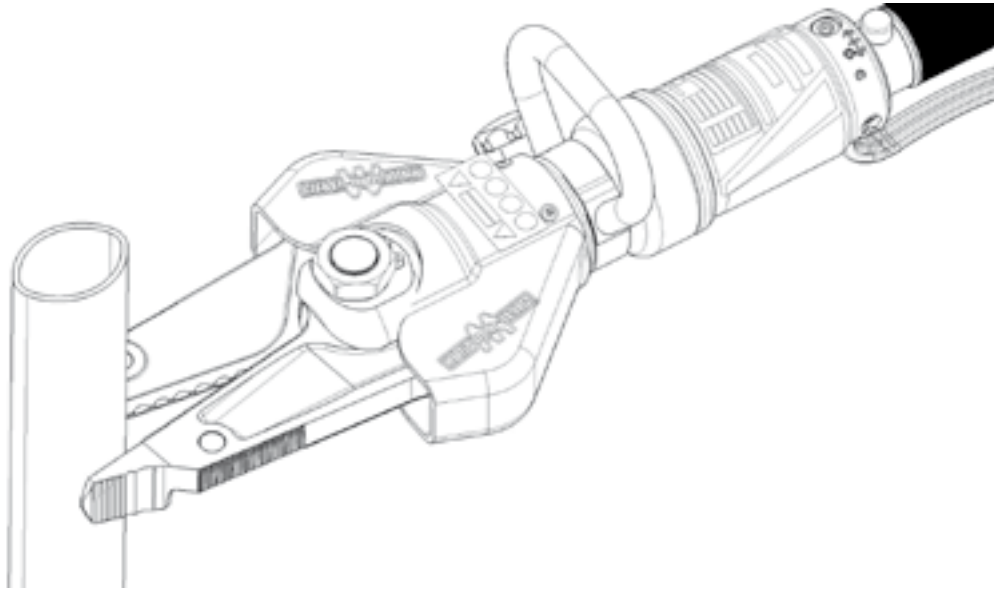

ATTENTION!

Material to be crushed can suddenly jump away.
Do not remain in the work area of the spreading and combi devices!



LIFTING (COMBI TOOLS)

The combi device can also be used for lifting vehicles or other movable loads. Care must be taken to secure the load against slipping away and to position the spreader tips far enough apart under the load to prevent slipping.

The load being lifted must be constantly monitored (tipping, rolling away or changing position). Also, the lifted load must immediately be propped up and supported in a suitable way.

CONTINUOUS CUTS (MTC)

Continuous Cuts are possible with the MTC without the need for time-consuming V-cuts. Here the special cutting device is set at right angles to the object to be cut (drive in from above) and the cutter driven closed.

It is necessary to ensure that the cut-out piece falls from the ejection aperture. Then open the cutter again and re-insert it into the same cut. It is possible to continue to work vertically downwards in this way.

TRANSPORT, PACKAGING AND STORAGE

Safety information



CAUTION!

Incorrect transport can cause damage!
Improper transport can cause significant material damage.

Therefore:

- » Proceed with caution when unloading the packages, and observe the symbols on the packaging.
- » Do not fully open and remove the package until it has reached its actual storage location.

Transport inspection

Upon receipt, the delivery should be checked immediately for completeness and damage during transport so that a quick remedy can be performed, if necessary.

If there is visible external damage, please proceed as follows:

- Do not accept the delivery, or only accept it with reservation.
- Note the extent of the transport damage on the transport documents or on the transport company's delivery note.
- File a complaint.



NOTE!

Report any defect as soon as it is detected.
Claims for damages can be directed to our customer service department.

DISPOSAL OF PACKAGING



All packaging materials and disassembled parts (transport protection) must be disposed of properly, in accordance with local regulations.

STORAGE

The equipment must be stored in a dry and dust-free environment, where possible. Avoid direct UV radiation to the hoses.



CAUTION!

The equipment must be stowed securely in the mountings provided in order to avoid damage during transit, etc.

INSTALLATION AND COMMISSIONING

Safety information



WARNING!

Danger of injury due to improper operation!
Improper operation can cause serious injury or material damage.

Therefore, make absolutely sure to:

- » All operating steps are executed in keeping with the information in this operating manual.
- » All covers and protective devices are installed and in proper working order prior to starting work.

Personal protective equipment

Wear the protective equipment for all work!



NOTE!

Special reference is made where it is necessary to wear additional protective equipment for certain work with or on the device.

CHECKING

Inspect the Cutter devices for damage. If the cutting device is not in pristine condition, it must not be used! In this case, immediately contact your supplier.

- Check the blades (damage)
- Check the control handle including pushbutton (function)
- Check the couplings (damage, dirt)
- Check the hand grip (securely fastened)
- Check the protective cover (damage)
- Check the hoses (damage)

INSTALLATION

Move both control levers on the hydraulic power unit to the „0“ position, pull off the dust protection cover on the coupling and connect the hydraulic hoses with the cutter as described in chapter 4.4. In order to avoid contamination then recouple the protective caps.

When using the OSC coupling can also be carried out without pressure („0“ position on power unit not necessary).

When operating a hydraulic power unit observe the operating instructions for the equipment!

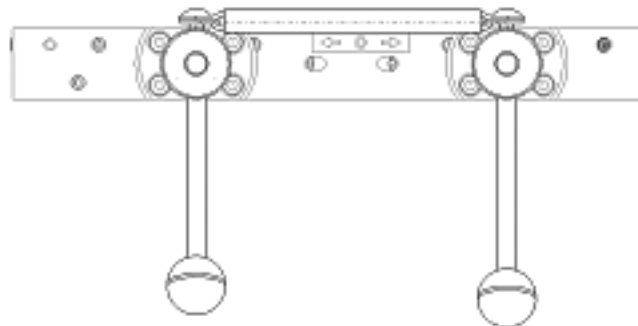

SHUT-DOWN (END OF WORK)

After work is over, the blade tips must be placed one above the other to prevent injury. The blades of the cutting device must not be completely closed, as otherwise tension will build up in the device.



NOTE !

With combi tools, drive the spreader arms to within a few millimetres of each other in order to relieve the hydraulics.

Then the equipment can be disconnected providing that the power unit control lever is in the „0“ position. Care must be taken to ensure that no dirt ends up on the coupling and that the protective caps are immediately fitted.

SERVICE

Safety information



WARNING!

Risk of injury due to improperly performed maintenance work!

Improper maintenance of the equipment can cause serious injury or material damage.

Therefore, make absolutely sure to:

- » Only let qualified personnel carry out maintenance work.
- » Make sure the installation site is organized and clean! Loose components and tools lying around are sources of danger.
- » Wear protective gloves for all work!

CARE AND MAINTENANCE

PREVENTATIVE MAINTENANCE

Genesis recommends that all hydraulic rescue tools be serviced by a certified factory technician at a frequency of once every 12 months. Just like a vehicle this crucial maintenance ensures the tool functions at top performance and safety. Your sales representative can answer any question you may have.

We recommend only qualified personnel carry out maintenance.

GENESIS PREVENTATIVE MAINTENANCE PROGRAM

The following are recommended service intervals for Genesis tools.

Each Use

- Equipment should be wiped down to remove debris
- Clean male and female couplers
- Clean cutter blades
- check whipends for damage
- check cutter blades for damage
- Check vario blades for damage
- Lubricate blades, pins and toggles with WD40 or equivalent

Weekly Inspections and Maintenance

- Check all couplers and fittings for tightness
- Run each tool and build pressure
- Check handles and guards, tighten if necessary
- Torque centerbolt on cutters

CARE AND MAINTENANCE

Annual Maintenance

- Change and replace the engines oil
- Change and replace the hydraulic fluid
- Test the engines performance
- Change the spark plug
- Clean and replace the air filter
- Lubricate moving parts
- Pressure check all lines and fittings
- Check opening and closing pressure
- Disassemble and examine all critical components
- Check the power units operating pressure
- Check all valves
- Provide loaner equipment during service
- Provide a detailed report



ATTENTION!

Prior to all maintenance work, the equipment must be cleaned of any dirt so that it does not get into the hydraulic system.



The cleaning can be carried out using a conventional citrus cleaner or using WD 40.

NOTE!

If there are any problems with the maintenance of the devices, contact your local sales representative.

TROUBLE SHOOTING

Fault	Possible cause	Remedial measures
Device does not reach full performance	Control buttons not fully depressed	Fully depress control buttons
Equipment delivers no power or moves in the opposite direction to that commanded	Pressure line (P) and return line (T) were transposed when hoses or couplings were replaced	Change round in accordance with the repair instructions
Cutter cannot be coupled	Pressure build-up due to heating (only SKS coupling) Coupling halves are damaged or heavily soiled	Drain a little oil out of the equipment with the pressure relief plug, see chapter 4.3 (only SKS coupling)
Oil escaping at the control handle (hole between the hoses)	Return hose is not correctly coupled (only SKS coupling)	Move power unit control lever to the "0" position and couple correctly (only SKS coupling)
Equipment non-functional despite actuating the control buttons	Pressure hose is not coupled	Move power unit control lever to the "0" position and couple correctly (only SKS coupling)
Combi tool exhibits movement in the opposite direction under load	Check non-return valve	Have the equipment checked by authorised customer services
Oil discharge on the hoses or their bondings	Hoses leaking, possibly due to damage	Replace hoses, see repair instructions
Degradation of the surfaces of the hoses	Contact with aggressive chemical fluids	Replace hoses, see repair instructions
Oil escaping at the coupling halves	Coupling leaking	Replace coupling, see repair instructions
Blades loose and gaping apart when cutting	Attachment of blades to the shearing head not in accordance with specifications	Repair by authorised customer service
Tip spread of cutter below target value	Shearing head settings incorrect	Repair by authorised customer service
Tip spread of combi tool below target value	Shearing head settings incorrect	Repair by authorised customer service
Pressure build up despite movement (open - closed) without any load	Hex nut / central bolt too firmly tightened	Repair by authorised customer service
Nick or gouge in blade	Blade damaged e.g. through cutting hardened materials	Can be reground up to approx. 2 mm (see repair instructions), otherwise replace
Chip or groove	Blade damaged e.g. through cutting high-strength materials	Have the blades replaced by authorised customer services

DECOMMISSIONING/RECYCLING

After the end of the normal service life, the equipment must be professionally disposed of. Individual parts can, however, certainly be used again.

The hydraulic oil must be completely drained and collected. Make sure that the hydraulic oil is disposed of separately!

For disposal of all device components and packaging materials, the disposal conditions of the specific location apply.

Do not discard electric tools with household waste!



NOTE!

Please ask your supplier about disposing of the device.

GENESIS

RESCUE SYSTEMS

**GENESIS RESCUE SYSTEMS
2780 CULVER AVE.
KETTERING, OHIO 45329
TEL: 1.937.293.6240
WWW.GENESISRESCUE.COM**